

Eric cot

Instruction manual

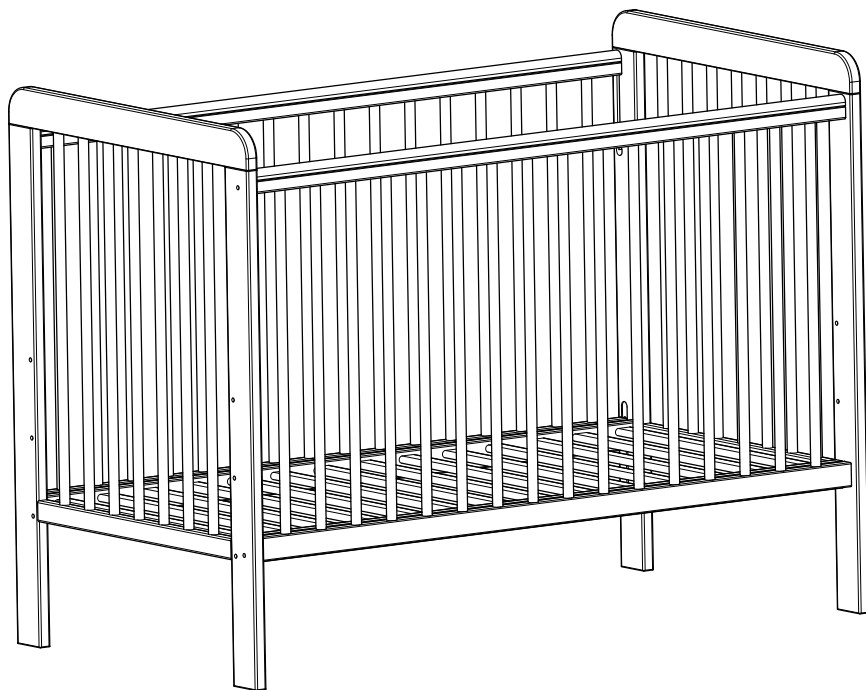

John Lewis

IMPORTANT
RETAIN FOR FUTURE REFERENCE
PLEASE READ CAREFULLY

Thank you for purchasing this Eric cot. Please read the instructions and warnings carefully before use to ensure safe and satisfactory operation of this product.

Your child's safety is your responsibility. If you have a query with this product or require replacement parts, please contact your nearest John Lewis department store.

Lay out the parts on a soft level surface and compare to the part/fixings checklist on page 2. Do not discard any packaging until you are sure that you have all the parts.

Keep children clear during assembly as pack contains small parts which may present a choking hazard.

Recommended mattress: 60 x 120cm

This product complies with BS EN 716 - 1: 2008 + A1 2013

Fixings

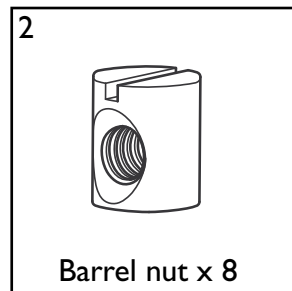
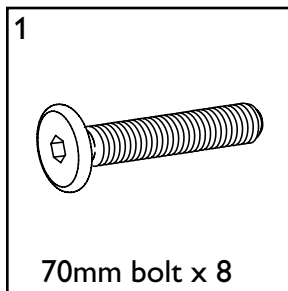

Parts

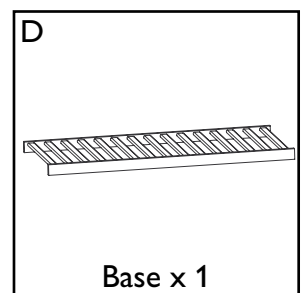
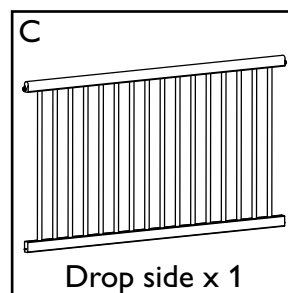
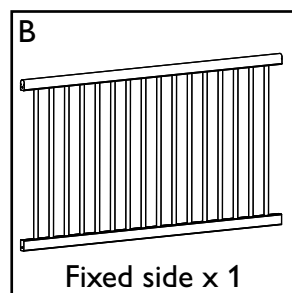
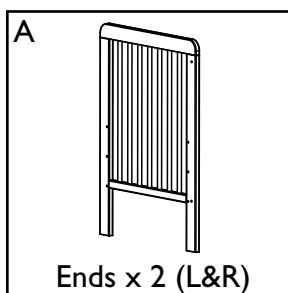

You will need:

1 x 6mm Allen Key (supplied)

Flat-headed screwdriver

Cot assembly - step 1

(Do not fully tighten bolts at this stage)

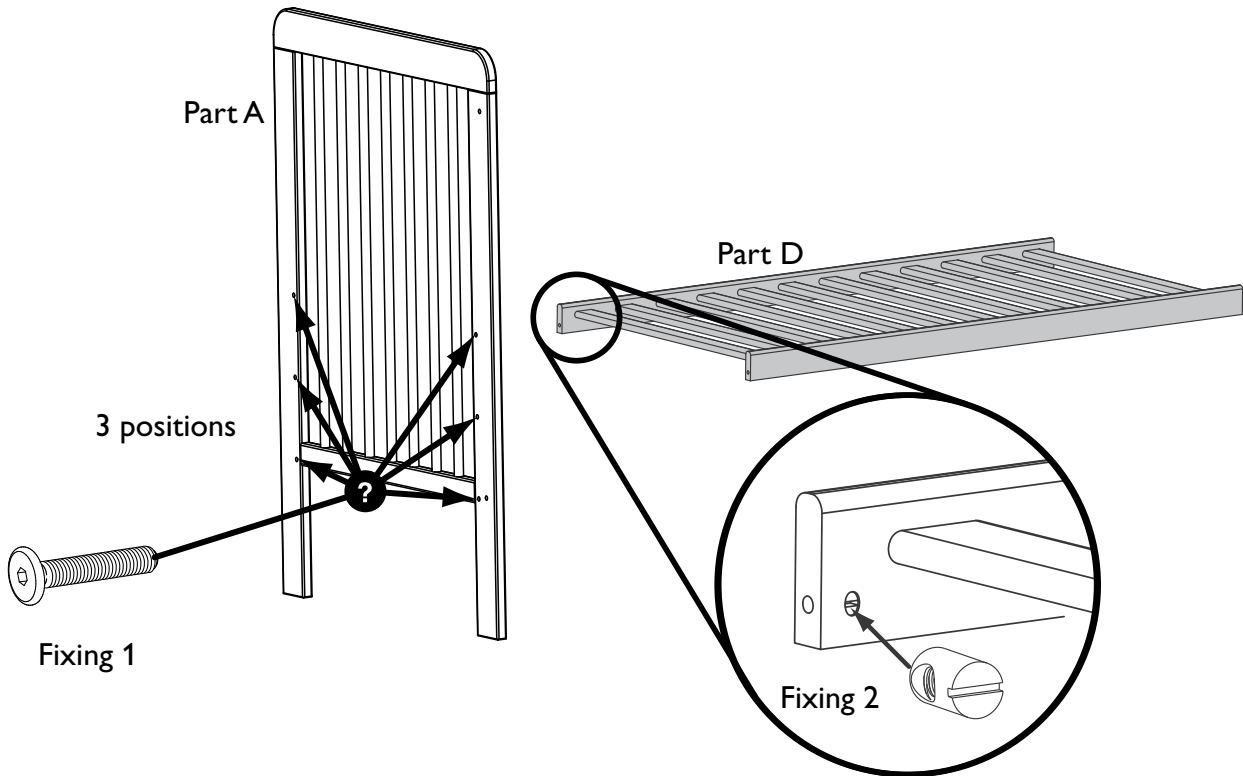

Push two barrel nuts (fixing 2) into the holes in the base (part D) as shown above. Make sure that the slots are visible and, if necessary, use a flat-headed screwdriver to ensure that the slots point towards the holes in the ends as shown. Select one of the 3 base heights and with the dropside slots facing inward, attach an end (part A) using two 70mm bolts (fixing 1). Do not fully tighten the bolts at this stage.

Cot assembly - step 2

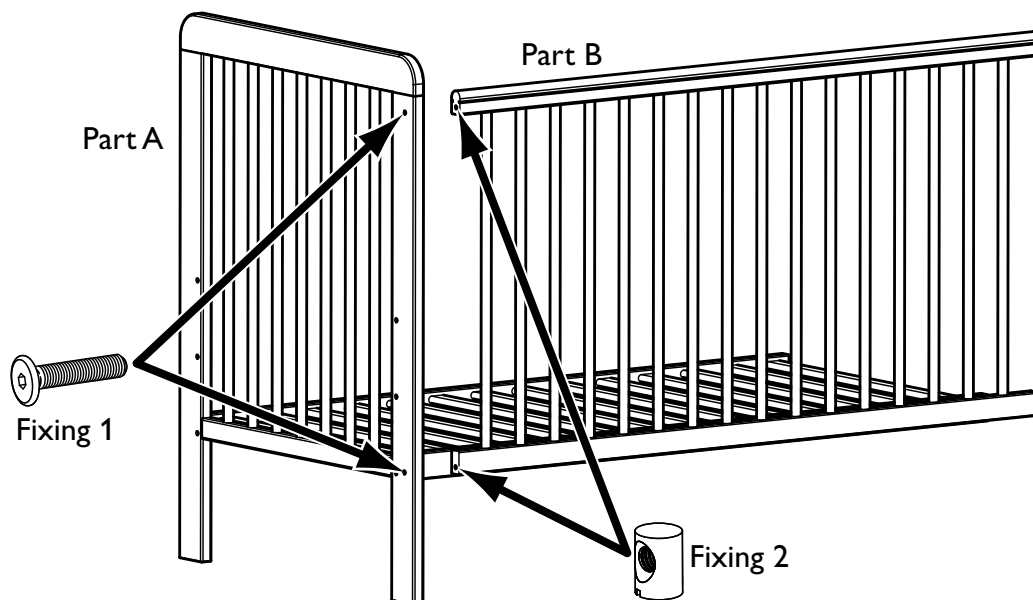

Push two barrel nuts (fixing 2) into the holes in the underside of the fixed cot side (part B), making sure the slots are visible and, if necessary, use a flat-headed screwdriver to ensure that the slots point towards the holes in the ends as shown. Attach the fixed cot side (part B) using two 70mm bolts (fixing 1) passed through the outer holes in the cot end (part A). Attach the second cot end (Part A) using the remaining bolts (Fixing 1) and barrel nuts (Fixing 2). Do not fully tighten the bolts at this stage.

Cot assembly - step 3

Diagram A

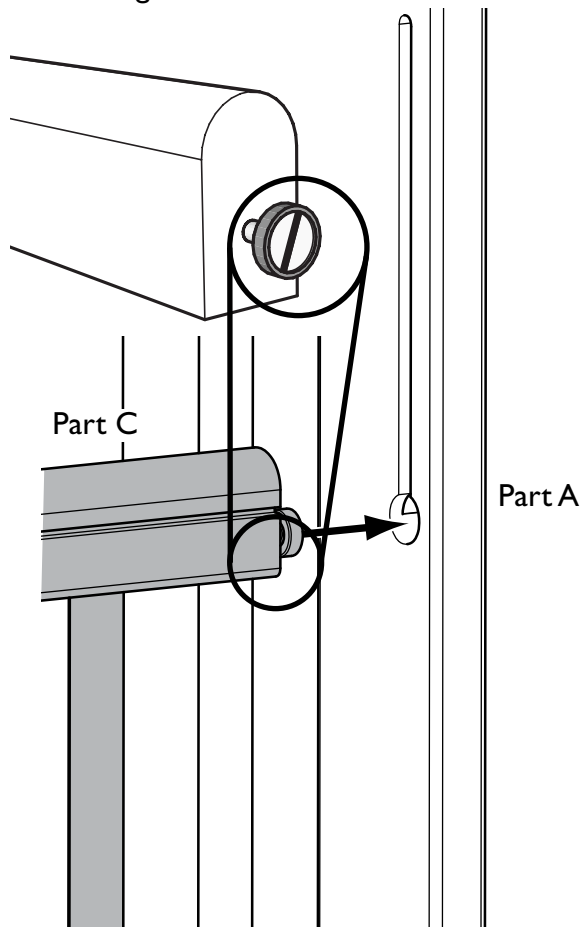
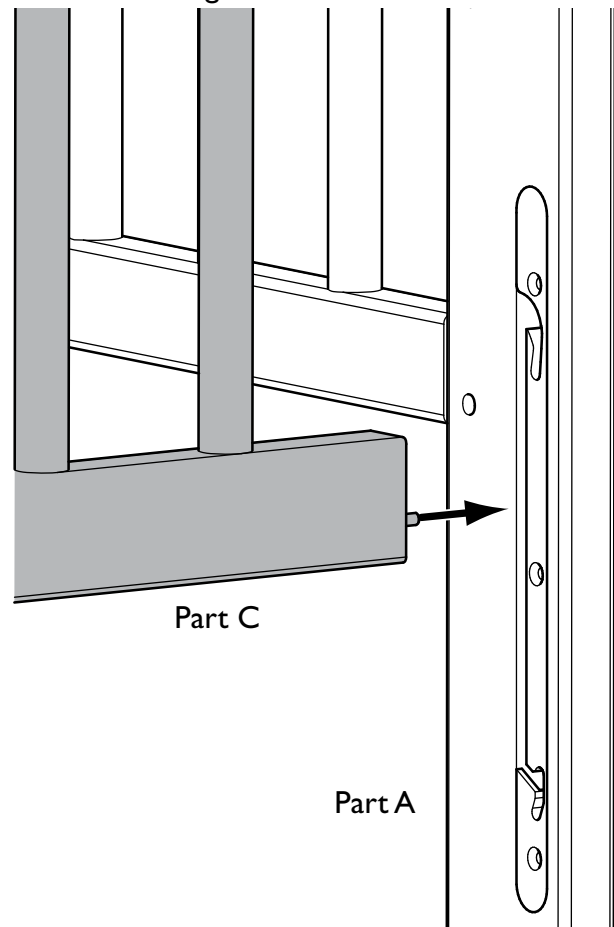

Diagram B



Make sure that the plastic caps on the drop side (Part C) are in position over the head of the pins in the upper rail of the drop side (Diagram A).

Ease the cot ends apart and making sure that the plastic caps remain in place, fit the top end pins of the drop side (Part C) fully into the lower end of the top slot in each end panel (Part A), as shown in diagram A.

Raise the drop side (Part C) to align the lower end pins with the lower grooves as shown in diagram B. Push the lower pins in against the spring pressure and locate them in the slots. The help of an assistant will make this stage easier.

Push all parts tightly together and fully tighten all bolts. Your cot is now ready for use.

NOTE: Take care when locating pins into lower grooves as the pin can easily damage the surface finish.

In use

To operate the Dropside;

Grasp the top rail in the centre and lift slightly.

Press the bottom of the dropside in with your leg - this will disengage the locks and allow the side to drop. To raise the side, lift the dropside slightly, push the bottom rail inward with your leg then lift again until the dropside clicks into place.

IMPORTANT: Always grasp the top rail in the centre to ensure that both locks engage and disengage.

A light application of furniture polish to the slots in the end panels will help ensure smooth operation of the dropside.

Care and maintenance

Your furniture may be cleaned by wiping with a damp cloth and drying with a soft clean cloth.

Do not use abrasives, bleach, alcohol or ammonia-based household polishes.

Take care when handling or moving the furniture. Careless handling may cause damage.

Safety notes

Furniture can be dangerous if incorrectly installed. Assembly should be carried out by a competent person.

Keep children clear during assembly as pack contains small parts which may present a choking hazard.

Warning: Be aware of the risks of open fires and other such sources of strong heat, such as electric bar fires, gas fires, etc. in the near vicinity of the cot.

Warning: Do not use the cot if any part is broken, torn or missing and use only spare parts approved by the manufacturer.

Warning: Do not leave anything in the cot or place the cot close to another product, which could provide a foothold or present a danger of suffocation or strangulation, e.g. strings, blind/curtain cords, etc.

Warning: Do not use more than one mattress in the cot.

The lowest base position is the safest and should be used as soon as your baby is old enough to sit up.

The thickness of the mattress chosen must not reduce the internal depth (from the top of the mattress surface to the top of the side) to less than 500mm with the base in its lowest position or 200mm with the base in the highest position.

The mattress should be no more than 30mm shorter or narrower than the internal length or width of the cot. Suitable for use with a mattress of 1200mm in length, 600mm in width and a maximum thickness of 100mm.

All assembly fixings should always be tightened properly. Periodically check all fixings to ensure none have come loose, and that there is no risk of clothing or parts of the body becoming snagged or trapped.

If you leave the child unattended in the cot, always make sure the dropside is in the raised position.

To prevent falls, when the child is able to climb out of the cot, the cot should no longer be used for that child.

Do not allow your child to jump on the cot. This may result in damage to the furniture and/or injury to your child.

Retain this information leaflet for future reference.

John Lewis Partnership
171 Victoria Street
London
SW1E 5NN

www.johnlewis.com